

## Detailing using Creo Parametric 3.0

### Overview

Course Code TRN-4505-T

Course Length 3 Days

In this course, you will learn how to quickly create detailed drawings using information captured within 3-D design models. You will also learn how to create drawings, how to detail drawings, and how to take advantage of the parametric and associative nature of Creo Parametric 3.0 when configuring drawings. After completing this course, you will be able to create production drawings suitable for manufacturing.

At the end of each module, you will complete a set of review questions to reinforce critical topics from that module. At the end of the course, you will complete a course assessment in Pro/FICIENCY intended to evaluate your understanding of the course as a whole.

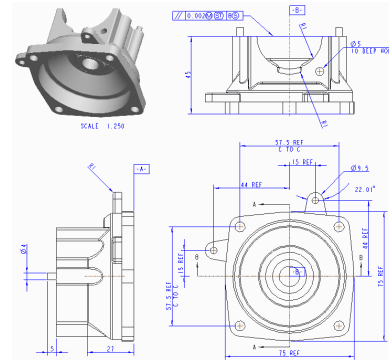

### Course Objectives

- Understand the drawing development process
- Create new drawings using formats and drawing templates
- Create different types of views in drawings
- Create dimensions and notes
- Control display options using layers
- Apply dimensional and geometric tolerances in drawings
- Add draft geometry and symbols to drawings
- Use layers in drawings to control the display of views and detail items
- Create drawing tables and a bill of materials
- Create drawing formats
- Configure the drawing environment
- Manage large drawings

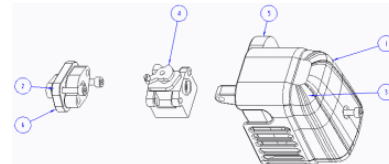

## Prerequisites

---

- Introduction to Creo Parametric 3.0

## Audience

---

- This course is intended for mechanical designers and design engineers. People in related roles will also benefit from taking this course.
-

## Agenda

### Day 1

---

Module	1	Introduction to Drawings
Module	2	Creating New Drawings
Module	3	Creating Drawing Views

### Day 2

---

Module	4	Adding Model Details to Drawings
Module	5	Adding Notes to Drawings
Module	6	Adding Tolerance Information
Module	7	Adding Draft Geometry and Symbols

### Day 3

---

Module	8	Using Layers in Drawings
Module	9	Creating and Using Tables in Drawings
Module	10	Using Report Information in Drawings
Module	11	Creating Drawing Formats
Module	12	Configuring the Drawing Environment
Module	13	Managing Large Drawings

---

## Course Content

### Module 1. Introduction to Drawings

- i. Understanding Drawing Concepts
- ii. Drawing Development Process
- iii. Understanding the Drawing Ribbon User Interface
- iv. Exploring Drawing Ribbon Commands

*Knowledge Check Questions*

### Module 2. Creating New Drawings

- i. Creating Drawings Using Formats and Sheets
- ii. Creating Drawing Templates
- iii. Creating Drawings Using Drawing Templates

*Knowledge Check Questions*

### Module 3. Creating Drawing Views

- i. Configuring Drawing Models
- ii. Configuring Drawing Sheets
- iii. Adding General Views
- iv. Adding Projection Views
- v. Editing Drawing Views
- vi. Editing Visible View Area
- vii. Adding Detailed Views
- viii. Adding Auxiliary Views
- ix. Understanding Cross-Section Concepts and View Types
- x. Adding 2-D Cross-Section Views
- xi. Modifying Cross Hatching Display
- xii. Adding Assembly Exploded Views

*Knowledge Check Questions*

### Module 4. Adding Model Details to Drawings

- i. Understanding Annotations in Drawings
- ii. Showing, Erasing, and Deleting Annotations
- iii. Inserting Driven Dimensions
- iv. Inserting Ordinate Dimensions
- v. Adjusting Dimensions and Detail Items
- vi. Changing Dimension Display

*Knowledge Check Questions*

### Module 5. Adding Notes to Drawings

- i. Adding and Editing Notes
- ii. Using Parametric Information and Special Characters in Notes

*Knowledge Check Questions*

### Module 6. Adding Tolerance Information

---

- i. Understanding Dimensional Tolerances
- ii. Configuring Dimensional Tolerances
- iii. Understanding Geometric Tolerances
- iv. Setting Up Geometric Tolerance References
- v. Applying Geometric Tolerances

*Knowledge Check Questions*

#### **Module 7. Adding Draft Geometry and Symbols**

- i. Creating and Editing Draft Geometry
- ii. Understanding Drawing Symbols
- iii. Using Surface Finish Symbols
- iv. Using the Symbol Palette and Custom Symbols
- v. Creating Symbols

*Knowledge Check Questions*

#### **Module 8. Using Layers in Drawings**

- i. Understanding Layers in Drawings
- ii. Using Layers in Drawings

*Knowledge Check Questions*

#### **Module 9. Creating and Using Tables in Drawings**

- i. Inserting Tables
- ii. Editing Table Properties
- iii. Creating Tables from File
- iv. Creating Hole Tables

*Knowledge Check Questions*

#### **Module 10. Using Report Information in Drawings**

- i. Creating Report Tables
- ii. Editing Report Tables
- iii. Creating BOM Balloons
- iv. Creating Part Catalog Drawings

*Knowledge Check Questions*

#### **Module 11. Creating Drawing Formats**

- i. Creating Drawing Formats

*Knowledge Check Questions*

#### **Module 12. Configuring the Drawing Environment**

- i. Configuring the Drawing Environment

*Knowledge Check Questions*

#### **Module 13. Managing Large Drawings**

- i. Understanding Drawing Regeneration
- ii. Managing Large Drawings

*Knowledge Check Questions*

---